

Modular Cooking Range Line EVO900 One Well Programmable Gas Fryer 23 liter with Pump, Lifting System and Automatic Cooking

ITEM # _____

MODEL # _____

NAME # _____

SIS # _____

AIA # _____



392343 (Z9KKLBAMCG)

23-lt gas fryer with 1 "V" shaped well (external heating elements), electronic control, programmable, oil recirculation pump, 2 half size baskets, automatic lifting system for baskets, automatic cooking function, predisposed for advanced filtering system

Short Form Specification

Item No. _____

High efficiency 25 kW burners in stainless steel. Suitable for natural gas or LPG. Deep drawn V-Shaped well and equipped with programmable electronic control panel. Automatic basket lifting system and automatic cooking mode. Unit predisposed for advanced filtering system to remove the smallest food residuals and extend the oil life. Oil drains through a tap into a container positioned under the well. Melting function to safely heat-up solid shortening used to fry products. Height adjustable feet in stainless steel. Exterior panels in stainless steel. Worktop in 20/10, stainless steel. Right-angled side edges eliminate gaps and possible dirt traps between units.

Main Features

- Deep drawn V-Shaped well.
- Built-in smart electronic control system to monitor the temperature during frying to guarantee the safety of the process.
- Overheat protection thermostat as standard on all units.
- Integrated oil filtering system with a pump for oil circulation.
- The unit is predisposed for ADVANCED FILTERING SYSTEM with paper filters to remove the smallest food residuals and extend the oil life.
- Unit to feature automatic basket lifting system and AUTOMATIC COOKING mode.
- Unit able to memorize 5 programs (temperature and time) and 5 extra programs can be customized using the automatic cooking mode allowing to adjust the cooking time automatically according to the load.
- All major compartments located in front of unit for ease of maintenance.
- Unit to be equipped with electronic control panel.
- The special design of the control panel offers a better guarantee against oil infiltration.
- Supplied as standard with 2 half size baskets and 1 right side door for cupboard.
- Thermostatic regulation of oil temperature up to a maximum of 190 °C.
- Optional portable oil quality monitoring tool (code 9B8081) for efficient oil management.

Construction

- All exterior panels in Stainless Steel with Scotch Brite finishing.
- Model has right-angled side edges to allow flush fitting joints between units, eliminating gaps and possible dirt traps.
- Interior of well with rounded corners for ease of cleaning.
- Unit is 900mm deep to give a larger working surface area.
- Unit delivered with four 50 mm legs in stainless steel as standard.

APPROVAL: _____

Included Accessories

- 1 of Stainless steel oil filter for 23 litres fryer to remove particles of grease and food residuals) - EVO900 PNC 200086
- 1 of DOOR FOR OPEN BASE CUPBOARD PNC 206350
- 1 of 2 half size baskets for 18/23lt well fryers PNC 927223

Optional Accessories

- Kit for advanced filtration system for 23-litre fryer, allowing to remove the smallest food residuals and extend oil life - EVO900 PNC 200084
- Pack of paper filter (100 pieces) for advanced filtration system for 23- litre fryer - EVO900 PNC 200085
- Stainless steel oil filter for 23 litres fryer to remove particles of grease and food residuals) - EVO900 PNC 200086
- Kit for 23-litre fryer, drain extension in high resistant elastomer with stainless steel extremities to drain oil - EVO900 PNC 200087
- Junction sealing kit PNC 206086
- Draught diverter, 120 mm diameter PNC 206126
- Matching ring for flue condenser, 120 -130 mm diameter PNC 206127
- 4 wheels, 2 swivelling with brake (EVO700/900). It is mandatory to install with base supports for feet/wheels. PNC 206135
- Flanged feet kit PNC 206136
- Pair of side kicking strips PNC 206180
- Frontal kicking strip for 23lt fryers in two parts PNC 206203
- Extension pipe for oil drainage for 15lt, 18lt, 23lt fryers PNC 206209
- Chimney upstand, 400 mm PNC 206303
- Flue condenser for 1/2 module, 120 mm diameter PNC 206310
- Base support for feet/wheels (lateral) for 23lt fryers and pastacookers and refrigerated bases (900) PNC 206372
- Sediment collection tray for 23 litres fryer (to be put in the well) - EVO900 PNC 921023
- 2 half baskets for 18/23lt fryers with front hook PNC 927200
- 1 full basket for 18/23lt fryers with front hook PNC 927201
- 2 half size baskets for 18/23lt well fryers PNC 927223
- Pressure regulator for gas units PNC 927225
- 1 full size basket for 18/23lt well fryers PNC 927226
- Unclogging rod for 23lt fryers drainage pipe PNC 927227
- Deflector for floured products for the 23lt fryer PNC 960645

Front

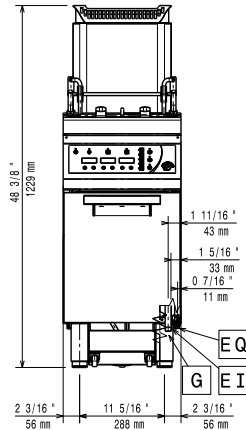

Side

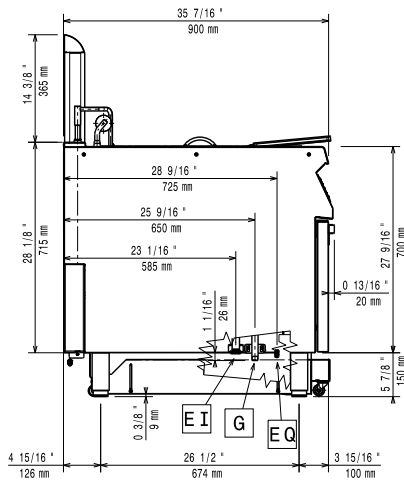

- EI = Electrical inlet (power)
- EQ = Equipotential screw
- G = Gas connection

Top

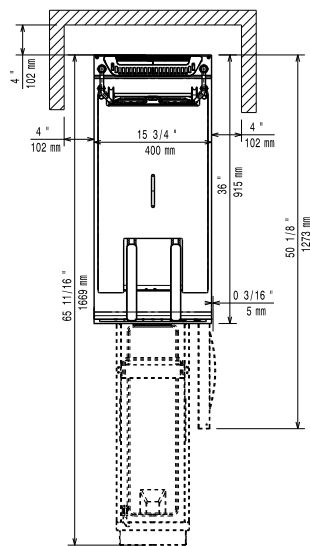

Gas

Gas Power:	392343 (Z9KKLBBAMCG)	26 kW
Standard gas delivery:		Natural Gas G20 (20mbar)
Gas Type Option:		LPG; Natural Gas
Gas Inlet:		1/2"

Key Information:

Usable well dimensions (width):	340 mm
Usable well dimensions (height):	575 mm
Usable well dimensions (depth):	400 mm
Well capacity:	21 lt MIN; 23 lt MAX
Performance*:	36.5 kg\hr
Thermostat Range:	110 °C MIN; 190 °C MAX
Net weight:	96 kg
Shipping weight:	108 kg
Shipping height:	1480 mm
Shipping width:	460 mm
Shipping depth:	1020 mm
Shipping volume:	0.69 m ³

If appliance is set up or next to or against temperature sensitive furniture or similar, a safety gap of approximately 150 mm should be maintained or some form of heat insulation fitted.

*Based on:	ASTM F1361-Deep fat fryers
Certification group:	GF91L23